

**EKOPOWER type Hukseflux LP02**  
**LOW COST SOLAR RADIATION SENSOR COMPLIANT**  
**WITH ISO AND WMO STANDARDS**

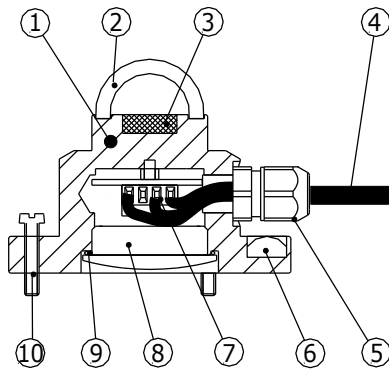

Figure 1 LP02 solar radiation sensor: (1) LP02 housing, (2) glass dome, (3) sensor, (4) cable, standard length 5 m, (7) screwed cable connection, (8) access for cable connection/ replacement.

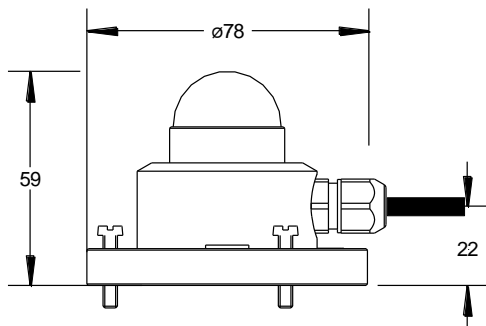

Figure 2 LP02 dimensions. Standard cable length is 5 m. All dimensions are in mm. Cable can be installed / replaced by the user.

LP02 is a solar radiation sensor that can be applied for most **common solar radiation observations**. It complies with the latest **ISO 9060** and WMO standards. The scientific name of this instrument is pyranometer. LP02 is a modern alternative for the so-called "star" or "black and white" pyranometers overcoming the problem of poor stability of the white reflective paint.

LP02 serves to measure the solar radiation flux that is incident on a plane surface in  $W/m^2$  from a 180 degrees field of view (also called "global" solar radiation). Working completely passive, using a thermopile sensor, LP02 generates a small output voltage proportional to this flux. Contrary to photodiode-based- and "black and white" instruments LP02 has a spectrally flat response across the full solar spectrum. Using LP02 is easy. For readout one only needs an accurate voltmeter that works in the millivolt range. To calculate the radiation level the voltage must be divided by the sensitivity; a constant that is supplied with each individual instrument. LP02 can directly be connected to most commonly used datalogging systems. LP02 can be used for general meteorological observations, building physics, climate- and solar collector testing. A common application is for outdoor solar radiation measurements as part of a meteorological station. This application requires horizontal levelling; levelling feet (7) and a level (11) are included. The LP02 cable can easily be installed or replaced by the user. Applicable standards are ISO 9060 and 9847, WMO (World Meteorological Organisation), and ASTM E824-94. LP02 can also be used for stability estimations according to EPA ( EPA-454/R-99-005).

**LP02 SPECIFICATIONS**

ISO classification:	second class
Spectral range:	305 to 2800 nm
Sensitivity (nominal):	15 $\mu V/Wm^{-2}$
Temperature range:	-40 to +80 °C
Range :	0 to 2000 $Wm^{-2}$
Temperature dependence:	< 0.1%/°C
Calibration traceability:	WRR

**OPTIONS**

- Additional cable length x metres (add to 5m)
- AMF 01 Albedometer Fixture (used with 2 x LP02)
- EKO21N and iBOX datalogger systems with intranet options and wireless 3G/GPRS